

PERAUN

Custom Applications

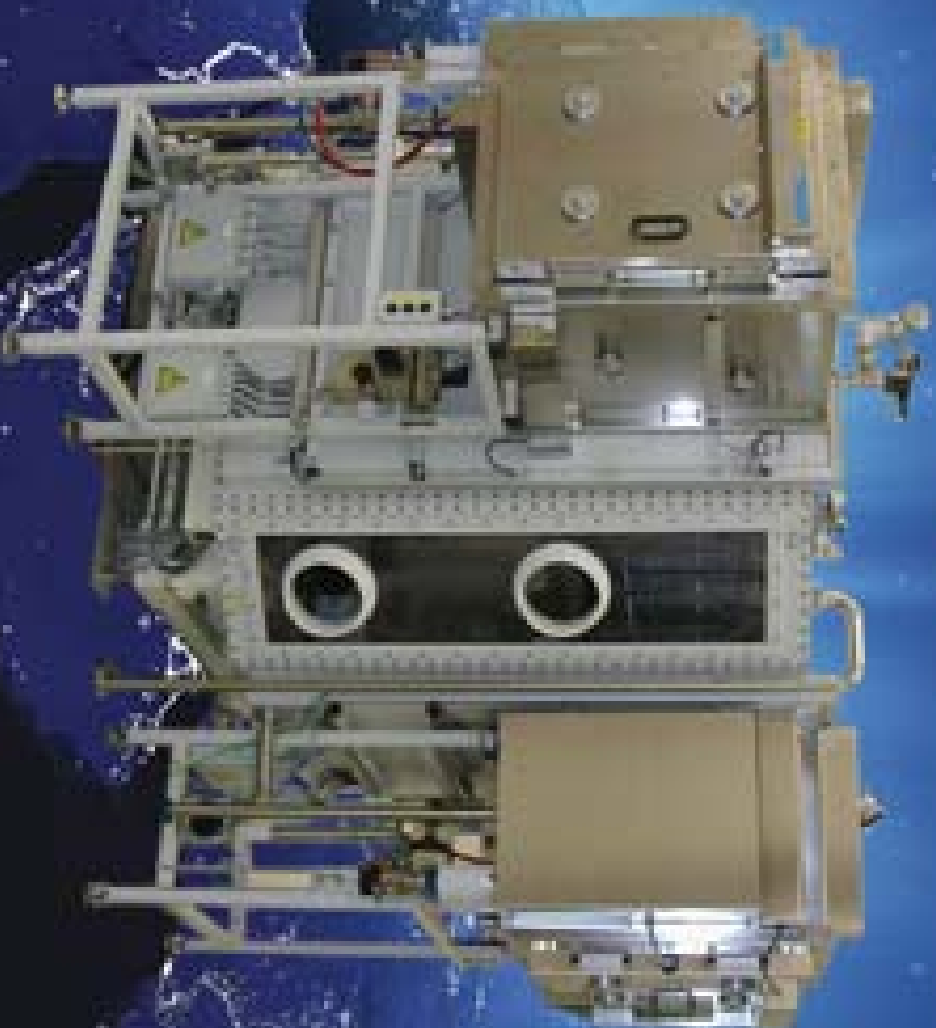

About MBraun:

MBraun is the world-wide leading manufacturer of gloveboxes, gas purification systems, solvent purifiers, evaporators, isolators and custom system solutions. We have a very diverse customer base which includes but is not limited to academic, industrial, pharmaceutical and government laboratories. MBraun is capable of designing and manufacturing a wide variety of glovebox systems. Our product line ranges from single person gloveboxes for basic laboratory research to totally custom fully automated glovebox production lines. With over thirty years experience, our expertise in controlled environments allows MBraun to provide the highest quality glovebox at the most competitive price.



Quality:

MBraun manufactures the highest quality glovebox system available in the industry. We have earned world-wide recognition through years of working together with our valued customers to ensure that our product quality exceeds expectations. MBraun is the industry leader in globally recognized quality certifications. MBraun's technical knowledge and design capabilities offer complete turnkey solutions for any challenge that our customer might face. Our precise attention to detail and vast knowledge of controlled atmosphere technology allow MBraun to provide the customer with the most reliable and highest quality glovebox systems.



World-wide Quality Certifications
ISO 9001:2000

Reliability / Capability:

MBraun gloveboxes are made from the highest quality materials providing the best possible reliability, dependability and functionality. MBraun offers fully trained service technicians to install your new system or upgrade your existing system. MBraun offers a free 24 hour/ 7 days a week technical service phone line to answer any technical questions you may have at any time of the day or night.

Engineering / Programming:

MBraun designs and manufactures custom glovebox systems for both the OEM and industrial customer. MBraun's extensive knowledge in controlled environments enables us to offer a custom system with more features and greater functionality. The engineering department at MBraun utilizes state-of-the-art design software programs and workstations.

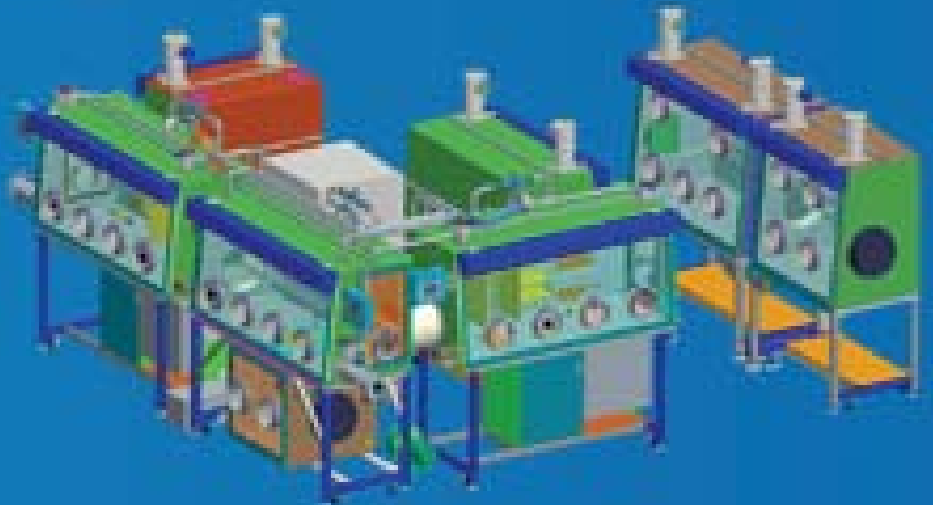

Custom Engineering

In addition, MBraun has the expertise and manufacturing resources necessary to custom design, prototype, and manufacture products based on your project requirements. Our dedicated and skilled engineers ensure that you get the optimal design for your application.

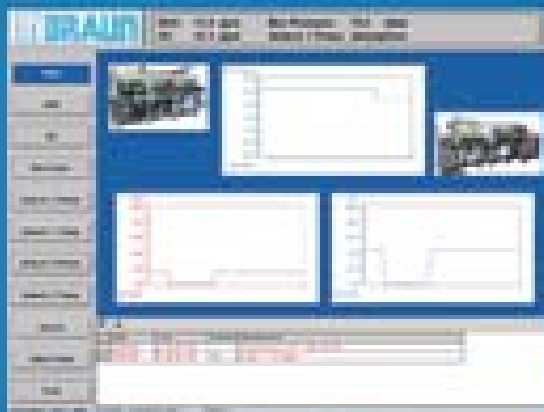

Programming Solutions

MBraun's engineering department can assist from the conceptual design up to market production for new technologies along with upgrades to existing production lines. MBraun also provides complete programming solutions for your custom system.

MBraun works regularly with third party manufacturers to design and integrate required components. MBraun would like the opportunity to help you meet today's emerging technology requirements. Contact MBraun to discuss your application needs.

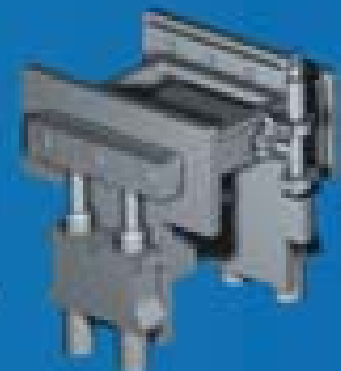

Product Development

MBRAUN

SCIENCE & RESEARCH

Our commitment to engineering, sales, service, and quality make MBraun the best choice in meeting your application specification. MBraun designs, develops and manufactures a wide variety of unique products tested to the most rigorous quality standards. A purchase from MBraun provides you and your research team with peace of mind along with the most repeatable results under any controlled environment. Our knowledge, experience and technology in controlled solutions is what sets MBraun apart from all other manufacturers.



Applications:

Sample preparation, metallography, thermal analysis, analytics, storage, preparation of intermetallic compounds and nitrides and nitridometalates, X-ray diffraction and more

WELDING

MBraun offers a comprehensive line of inert gas components for welding applications. This program comprises of special welding boxes for resistance welding, laser welding with protective vitrification, plasma welding with nitrogen free argon environment and special feedthroughs for necessary supply lines. MBraun manufactures particle removal units with continuously active separation, plasma welding heads amongst other accessories for fusing of quartz glass when manufacturing metal halogenated lamps (MHL). MBraun can supply welding gloveboxes for a wide variety of customers and applications.



Jet Turbine Repair



Laser Welding



Standard Welding Glovebox

LAMP SEALING

MBraun offers glovebox systems and special equipment for HID lamp development and production. The lamps can be made of quartz glass or ceramics. In the production environment MBraun can remove oxygen, moisture, nitrogen and dust by MBraun's powerful gas purification systems MB 300, MB 200N and the Clean Jet series. MBraun also offers fully automated transport and loading systems for production lines. In addition, MBraun manufactures lamp research systems used for the cleaning, gas filling and sealing of glass or ceramic tubes in high temperature ovens. All production steps can be developed in a flexible glovebox system offering access to a variety of lamp production parameters.



Lamp Sealing Production Line

PHARMACEUTICAL

MECALAB the "isolator trademark" of the MBraun Group, stands for quality, experience and reliability. MBraun is capable of providing turnkey solutions to the Pharmaceutical market offering optimally designed isolators and equipment to meet the needs of the customer. Isolator options include explosion proof components, radial rounded corners, laminar flow, protection from the product and user, variable filter systems, electronic and mechanical pressure regulators, filter dryers, alpha/beta ports, CIP systems and more. MBraun can design and manufacture an isolator that meets your needs. Contact MBraun to discuss your application.



Pharmaceutical Isolators

BATTERY

With battery production and development in high demand, let MBraun engineer and manufacture a glovebox that meets your specific application requirements. In an MBraun glovebox, batteries can be produced without the risk of contamination. Unlike dry rooms the moisture content in a glovebox is uniform, controlled, measured and independent from the number of operators working in the production room. In an MBraun glovebox the water content is below 1 ppm i.e. below -75°C or below -100°F . MBraun offers a full line of modular and customized gloveboxes for all your production and research needs. MBraun regularly works with different equipment manufacturers for battery production lines while providing complete turnkey systems that meet your unique specifications.



Battery Production Line

NUCLEAR

MBraun manufactures gloveboxes and/or barrier systems for the filtration of nuclear sewage. The nuclear marketplace is in high demand for a controlled environment system made from the highest quality components.

MBraun gloveboxes protect the user from exposure and allows for safe handling of dangerous material. MBraun manufactures to your specifications and meets your demands in technology, safety and reliability. In addition, MBraun manufactures tritium retention systems designed to purify hermetically enclosed atmospheres containing tritiated chemical species.

MBraun manufactures tritium retention systems designed to purify hermetically enclosed atmospheres containing tritiated chemical species.



Gloveboxes Operated under Negative Pressure



Tritium Retention Systems

OLED/PLED

MBraun builds laboratory scale gloveboxes up to production scale glovebox systems for the OLED/PLED marketplace. With extensive knowledge in the manufacturing of high temperature ovens and incorporating automation into our gloveboxes MBraun is the best choice in all your OLED/PLED needs. The MBraun modular glovebox system provides a complete enclosure of encapsulation and getter lines, which is quite cost effective and a flexible solution for fast changing production demands. The glovebox system comes with stand alone gas purification units for a wide range of glovebox configurations.



OLED/PLED Production
w/ IGMS Gas Purification



Integrated
Ovens



OLED/PLED Production Line

MEDICAL

MBraun provides an extensive line of gloveboxes for medical applications. MBraun gloveboxes are currently used for the packaging of sensitive materials such as contact lenses, medical tools and devices. Other medical products like the pace maker and artificial heart utilize the glovebox as well because of the high quality and repeatable results. MBraun offers the best technology in controlled environments, which is why medical corporations have used MBraun for all their controlled environment needs.



Gloveboxes for Medical Research

Germany



M.Braun Inertgas-Systeme GmbH (Headquarters)
Dieselstr. 31 • D-85748 Garching • Germany
Phone: +49 89 32669-0 • Fax: +49 89 32669-105
www.mbraun.de • info@mbraun.de

USA



M.Braun Incorporated
14 Marin Way • Stratham, NH • 03885
Phone: 603-773-9333 • Fax: 603-773-0008
www.mbraunusa.com • info@mbraunusa.com

USA West



M.Braun West Coast Office
Suite 206
2570 North First Street • San Jose, CA • 95131
Phone: 408-273-4594 • Fax: 408-273-4694
www.mbraunusa.com • info@mbraunusa.com

U.K & Ireland



M.Braun UK & Ireland
Mansfield Business Center • Ashfield Avenue • Mansfield
Nottinghamshire • NG18 2AE • United Kingdom
Phone: +44 (0)1623 404329 • Fax: +44 (0)1623 404277
www.mbraun.co.uk • p.bane@mbraun.de

China



M.Braun Inertgas Systems Co. Ltd. (Shanghai)
828 Xin Jinqiao Road • Pudong Shanghai 201206 • P.R.C
Phone: +86 21 5032 02 57 • Fax: +86 21 5032 02 29
www.mbraunchina.com • info@mbraunchina.com

Switzerland



MECALAB-M.BRAUN AG
Büdengasse 22 • CH-2540 Grenchen • Switzerland
Phone: +41 (0)32 654 22 66 • Fax: +41 (0)32 654 22 77
www.mecalab.com • info@mecalab.com